

MasterMover®

TOW300 SS

Battery powered electric tow tug



TOW300 SS



Overview

The Stainless Steel range of electric tugs delivers the same level of performance as our mild steel ranges, but with the added benefit of seamlessly integrating into sterile environments.

Whether it's a biopharmaceutical cleanroom suite or a food manufacturing facility, our stainless steel electric tugs remove manual handling and drive operational efficiency without compromising the cleanliness of your facility.

Constructed from high-grade 316 stainless steel and with IP ratings of up to IP55 available, stainless steel electric tugs are ideally suited to the stringent requirements of sterile environments.

The Stainless Steel range of electric tow tugs facilitate the controlled movement of loads in tight spaces, with an array of coupling options available that put load security and safety at the forefront.

Key Features

Safety

- Audible horn, flashing safety light, emergency stop button and anti-crush button
- Speed control with an optional two-speed selector switch for maximum control
- Complete load security with automatic braking

Power

- Optimised motor output to optimise speed and power
- Maintenance-free, interchangeable battery options
- Powerful, effective, traction generation for smooth performance

Performance

- Powerful weight-moving capabilities suited to every application
- Maximum traction even on wet floors
- Compact and manoeuvrable to deliver precise movements in even the tightest of spaces

Connection

- Secure coupling systems to deliver the controlled movement of loads
- A range of coupling options available to connect to a variety of loads
- Custom couplings available



Dimensions

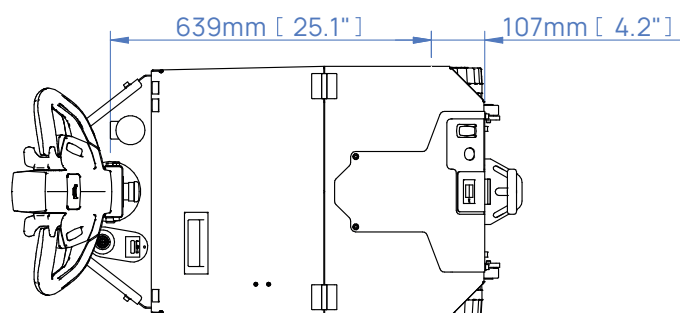
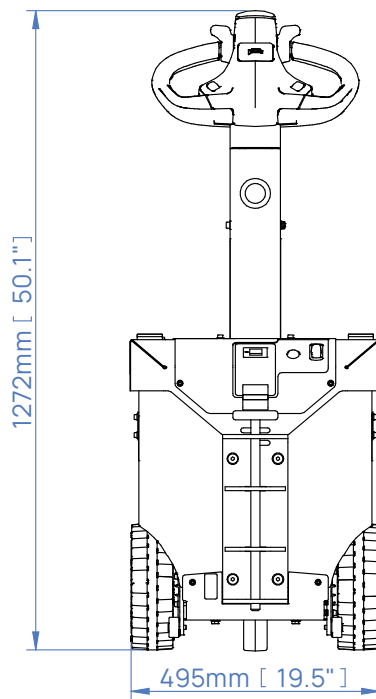
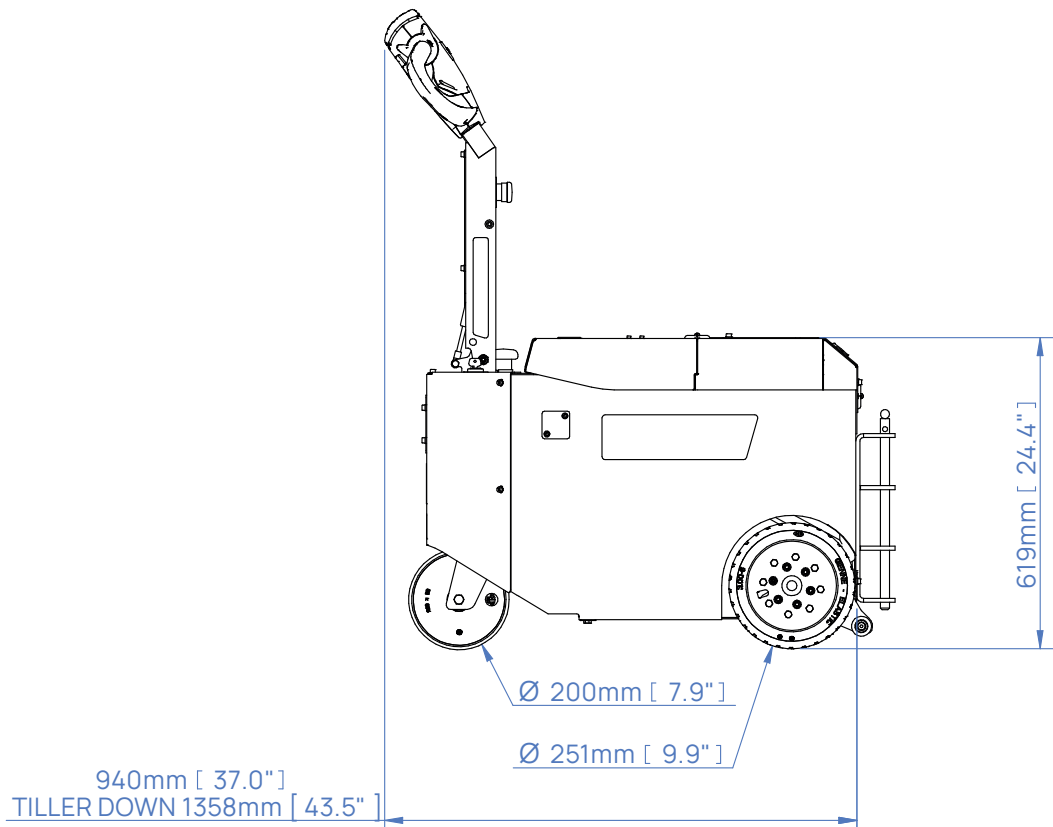

Slope Performance



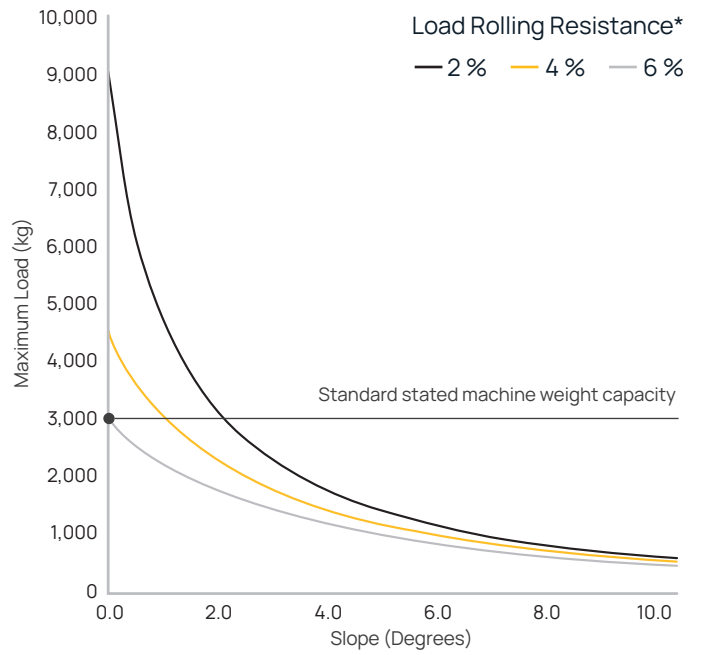

The force required to move a load is based on load weight, slope angle and floor condition. Movement on a slope increases the force required to safely start, stop and move the load.

If your application involves moving a load up or down a slope, speak to our team who will be happy to advise on which machine will meet your requirements.





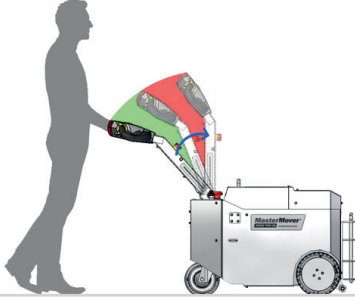
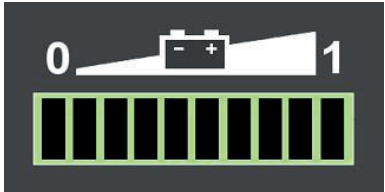

* Variables that affect rolling resistance include the quality of floor/terrain and the type/condition/quality of castor wheels.

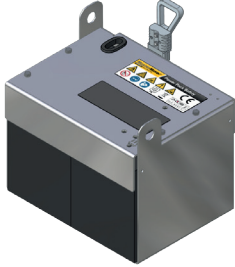

Standard Safety Features

<p>Emergency Stop Button</p> 	<p>Anti-Crush Button</p> 	<p>Warning Horn</p> 
<p>Automatic Parking Brake</p> 	<p>Automatic Cut Off</p> 	<p>Battery Discharge Indicator</p> 
<p>Key Switch</p> 		

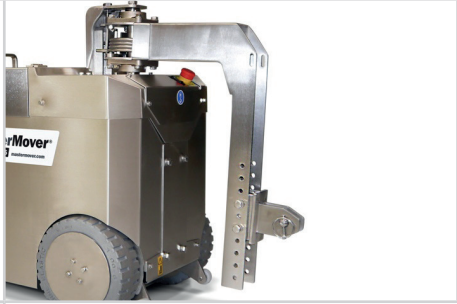
Machine Options

<p>Additional AGM Battery Z79-00300</p>	<p>Flashing Light & Motion Beeper Z79-00500</p>	<p>Machine Crawl Coupling Assist Z79-00501</p>
		
<p>Two Speed Selector Switch Z79-00505</p>	<p>Remote Control Z79-00504</p>	<p>Fifth Wheel Z79-00503</p>
		
<p>Battery Protection System Z79-00508</p>	<p>Steer Mode Switch Z79-00502</p>	
		

Couplings

Pin Coupling
Z79-00600 male

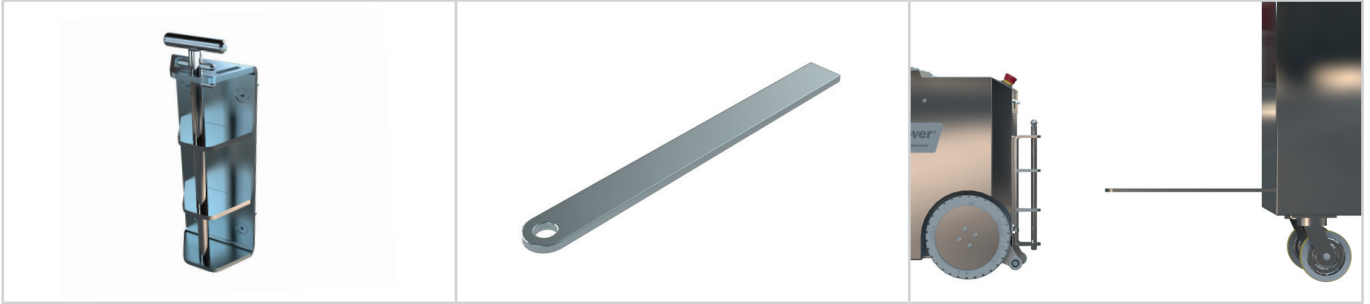

Tow Arm Coupling
Z79-00602 male



Box Coupling
Z79-00603 male | Z79-00700 female



No Coupling Z79-00604

Custom Engineering

We understand that every application is different. Whether it's a custom coupling to connect to your load, modifying our electric tugs to work in a challenging environment, or designing an entirely new solution for your application, our Customer Engineering team are here to help.

For more information on our custom engineering capabilities, please visit: mastermover.com/custom-solutions
If you'd like to discuss your requirements, speak to your sales representative or email: sales@mastermover.com

Technical Specification

Machine	
Product code	Z79-00101
Maximum load (on castors on rails)	3,000 kg 12,000 kg
Maximum force (push pull)	1,177 N 1,765 N
Machine weight	343 kg
Battery weight (standard)	54 kg
Combined machine & battery weight (standard)	397 kg
Drive type	Electric
Braking	Regenerative
Parking brake	Electromagnetic
Drive wheel type	Solid Rubber
Castor wheel type	Polyurethane
Drive wheel diameter	260 mm
Drive motor power	0.8 kW
Controller type	DC
Standard machine speed (Without two speed selector switch)	2 KPH
Hare mode speed (With two speed selector switch)	3 KPH
Tortoise mode speed (With two speed selector switch)	1.2 KPH
Maximum slope	10°
Voltage	24 v
Noise level	Motor ≤80 dBA Flashing light ≤85 dBA Horn ≤112 dBA
Metal work finish	Stainless Steel 316 grade, 240-grit abrasive to 0.6μ satin finish
IP rating	IP55
AGM Battery	
Product code	Z79-00300
Battery pack capacity	73 Ah
Maximum distance per charge*	11.8 km
Charge time (External Internal charger)	5 hrs 30 mins 5 hrs 30 mins
External Charger	
Product code	Z79-00400
Input voltage	85 - 265 v
Hertz	50 - 60 Hz
Amps	15 A
Phase (single, three)	Single
IP Rating	IP30
Internal Charging	
Product code	Z79-00401
Input voltage	85 - 265 v
Hertz	50 - 60 Hz

Technical Specification

Amps	15 A
Phase (single, three)	Single
IP rating	IP30
Lithium Battery	
Product code	Z49-00301
Battery pack capacity	79 Ah
Maximum distance per charge*	12.8 km
Charge time (External charger)	2 hrs
External Charging	
Product code	Z79-00402
Input voltage	85 - 265 v
Hertz	50 - 60 Hz
Amps	40 A
Phase (single, three)	Single
IP rating	IP30
Coupling	
Pin Coupling (male)	Optional
Tow Arm Coupling (male)	Optional
Box Coupling (male I female)	Optional
No Coupling	Optional
Safety	
Key Switch	Standard
Emergency Stop	Standard
Battery Discharge Indicator	Standard
Anti-Crush Button	Standard
Warning Horn	Standard
Automatic Cut Off (as tiller arm returns to vertical)	Standard
Automatic Parking Brake	Standard
Integrated Lifting Points	Standard
Intergrated Tie-Down Points	Standard
Options	
Additional AGM Battery	Optional
Flashing Safety Light and Motion Bleeper	Optional
Machine Crawl Coupling Assist	Optional
Fifth Wheel	Optional
Two Speed Selector Switch	Optional
Battery Protection System	Optional
Remote Control	Optional
Steer Switch Mode	Optional

MasterMover®

mastermover.com

© Copyright 2023

UK
CA   