

**MasterMover®**

# TMS2000+

Electric trailer mover



# TMS2000+



## Overview

The Trailer Moving System is specifically designed to move unladen trailers. From articulated trailers to flat beds and low loaders, the TMS range of electric tugs allow the effortless movement of heavy trailers inside, outside and on slopes.

Featuring a universal kingpin connection, the Trailer Moving System connects securely to any commercial trailer. Once securely connected, the Trailer Moving System safely raises one end of the trailer off the ground, enabling a full range of movement.

Fully electric and license-free, the Trailer Moving System prevents bottlenecks in moving trailers for both distribution depots and manufacturers alike. Boasting intuitive operator controls and safety built-in as standard, the range provides operators with complete control when moving heavy trailers. A compact machine design maximises visibility and enables operators to easily manoeuvre large commercial trailers in even the tightest of spaces.

An optional air compressor is also available, enabling operators to control the trailer brakes directly from the electric tug.

## Key Features

### Safety

- Audible horn, flashing light beacon, and emergency stop
- Multiple speed settings for complete control
- Anti-crush system

### Performance

- Powerful movement of trailers weighing up to 20,000kg
- Consistent performance inside, outside and on slopes
- Optional air compressor to engage trailer brakes

### Power

- Emissions-free operation
- High-performance, maintenance-free batteries
- Battery discharge indicator for real-time battery status

### Connection

- Utilises industry-standard kingpin connection
- Secure locking system guarantees total load security
- Powerful hydraulic kingpin lift system



# Dimensions

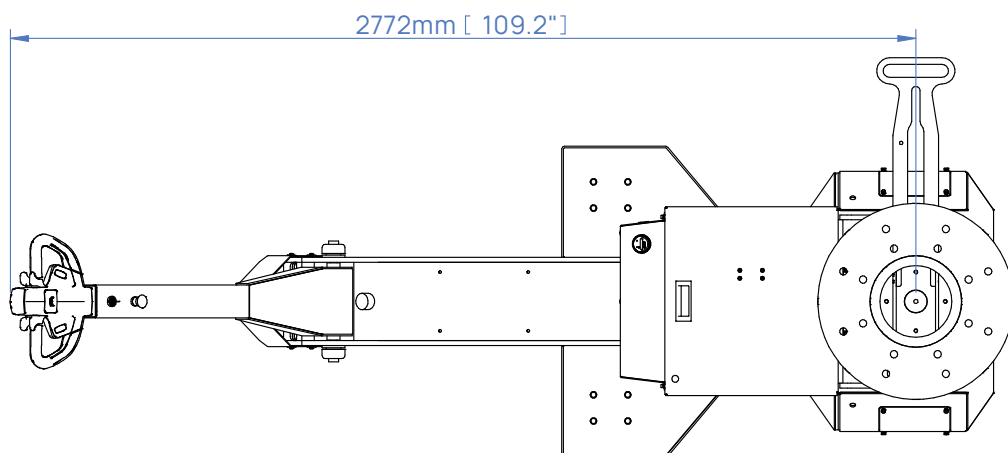
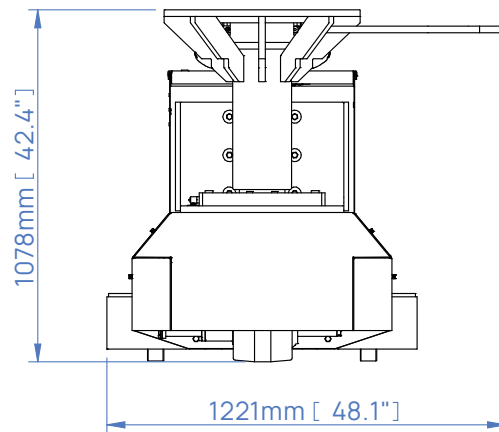
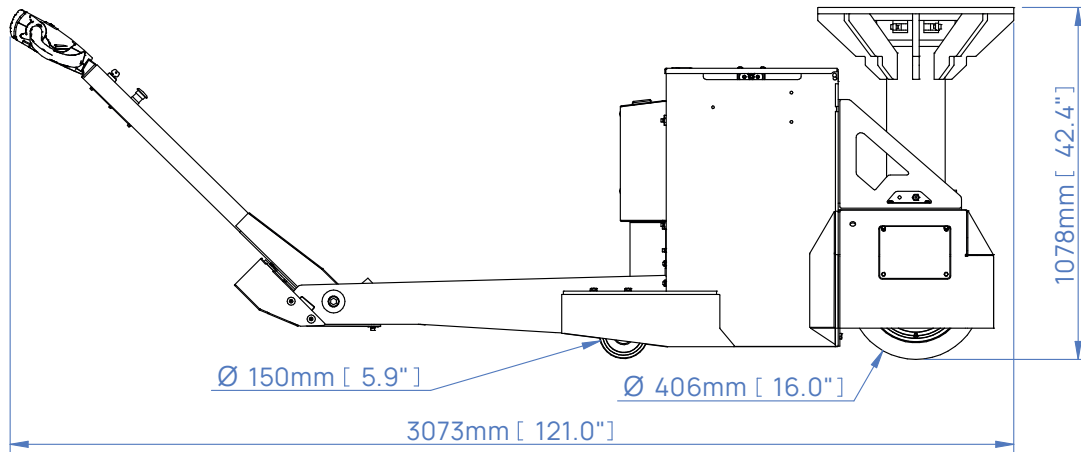







# In Application: Trailer Moving System





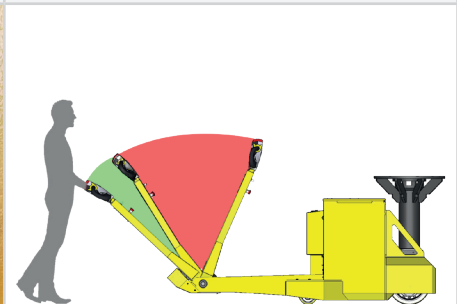

# Standard Safety Features

Emergency Stop	Anti-Crush Button	Warning Horn
		
Automatic Parking Brake	Battery Discharge Indicator	Automatic Cut Off
		
Key Switch		
		

# Machine Options

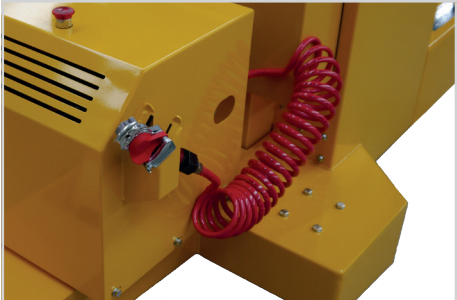
<p>Flashing Light &amp; Motion Beeper Z25-00500</p>	<p>Two Speed Selector Switch Z25-00501</p>	<p>Lift and Tie-Down Points Z25-00502</p>
		
<p>Quick Release Air Compressor Z25-00503</p> 		

# Couplings

Mast - 50mm king pin  
Z25-00200 male

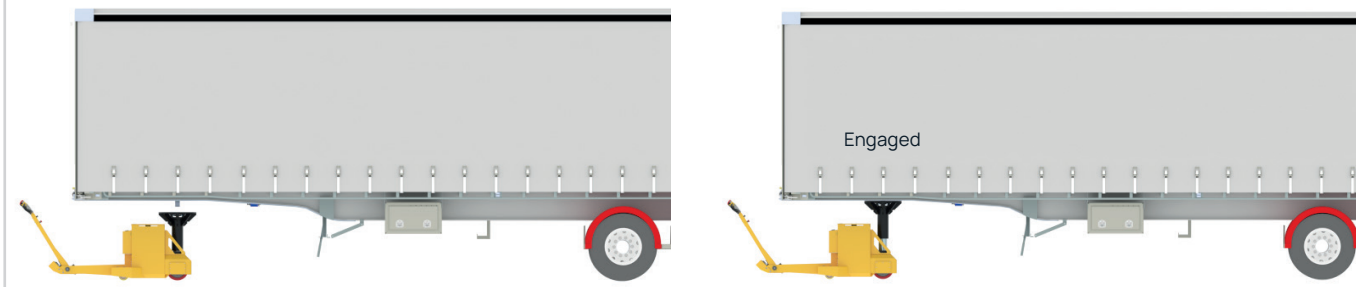

Mast - 90mm king pin  
Z25-00201 male

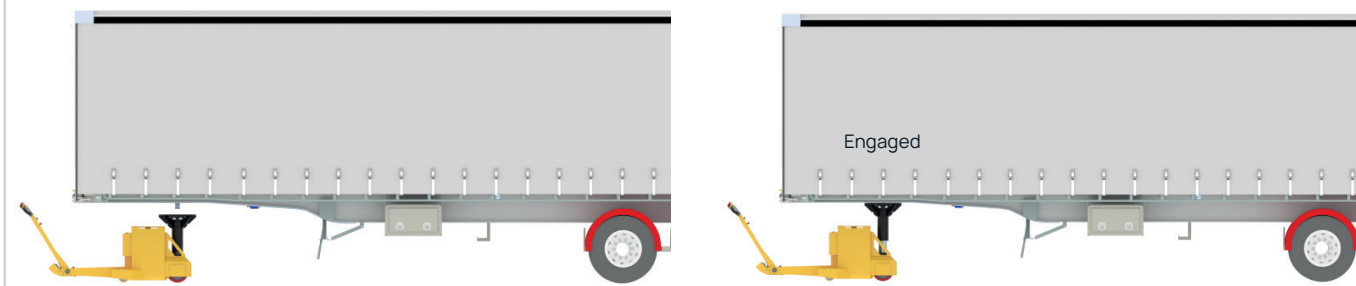

## Custom Engineering

We understand that every application is different. Whether it's a custom coupling to connect to your load, modifying our electric tugs to work in a challenging environment, or designing an entirely new solution for your application, our Customer Engineering team are here to help.

For more information on our custom engineering capabilities, please visit: [mastermover.com/custom-solutions](https://mastermover.com/custom-solutions)  
If you'd like to discuss your requirements, speak to your sales representative or email: [sales@mastermover.com](mailto:sales@mastermover.com)

# Technical Specification

Machine	
Product code	Z25-00101
Maximum load (on castors   on rails)	20,000 kg   80,000 kg
Maximum force (push   pull)	19,129 N   19,129 N
Machine weight	854 kg
Battery weight (standard)	249 kg
Combined machine & battery weight (standard)	1,103 kg
Drive type	Electric
Braking	Regenerative
Parking brake	Electromagnetic
Drive wheel type	Non-marking Polyurethane
Castor wheel type	Steel
Drive wheel diameter	406 mm
Drive motor power	8 kW
Controller type	AC
Standard machine speed (Without two speed selector switch)	2 KPH
Hare mode speed (With two speed selector switch)	3 KPH
Tortoise mode speed (With two speed selector switch)	1.2 KPH
Maximum slope	7°
Voltage	48 v
Noise level	Motor ≤80 dBA   Flashing light ≤85 dBA   Horn ≤112 dBA
Metal work finish	Powder coat paint & zinc plated
IP rating	IP44
AGM Battery	
Product code	Z25-00300
Battery pack capacity	120 Ah
Maximum distance per charge*	6.3 km
Charge time	6 hrs
External Charger	
Product code	Z25-00400
Input voltage	85 - 265 v
Hertz	50 - 60 Hz
Amps	20 A
Phase (single, three)	Single
IP Rating	IP30



# Technical Specification

Coupling	
Mast 50mm King Pin (male)	Optional
Mast 90mm King Pin (male)	Optional
Safety	
Key Switch	Standard
Emergency Stop Button	Standard
Battery Discharge Indicator	Standard
Anti-crush Button	Standard
Automatic Parking Brake	Standard
Warning Horn	Standard
Automatic Cut Off (as tiller arm returns to vertical)	Standard
Options	
Flashing Safety Light and Motion Bleeper	Optional
Two Speed Selector Switch	Optional
Lift and Tie-Down Points	Optional
Quick Release Air Compressor	Optional

**MasterMover®**

mastermover.com

© Copyright 2023

UK  
CA

CE

ISO 9001

ISO 45001