

MasterMover®

TMS1100+

Electric trailer mover



TMS1100+



Overview

The Trailer Moving System is specifically designed to move unladen trailers. From articulated trailers to flat beds and low loaders, the TMS range of electric tugs allow the effortless movement of heavy trailers inside, outside and on slopes.

Featuring a universal kingpin connection, the Trailer Moving System connects securely to any commercial trailer. Once securely connected, the Trailer Moving System safely raises one end of the trailer off the ground, enabling a full range of movement.

Fully electric and license-free, the Trailer Moving System prevents bottlenecks in moving trailers for both distribution depots and manufacturers alike. Boasting intuitive operator controls and safety built-in as standard, the range provides operators with complete control when moving heavy trailers. A compact machine design maximises visibility and enables operators to easily manoeuvre large commercial trailers in even the tightest of spaces.

An optional air compressor is also available, enabling operators to control the trailer brakes directly from the electric tug.

Key Features

Safety

- Audible horn, flashing light beacon, and emergency stop
- Multiple speed settings for complete control
- Anti-crush system

Performance

- Powerful movement of trailers weighing up to 20,000kg
- Consistent performance inside, outside and on slopes
- Optional air compressor to engage trailer brakes

Power

- Emissions-free operation
- High-performance, maintenance-free batteries
- Battery discharge indicator for real-time battery status

Connection

- Utilises industry-standard kingpin connection
- Secure locking system guarantees total load security
- Powerful hydraulic kingpin lift system





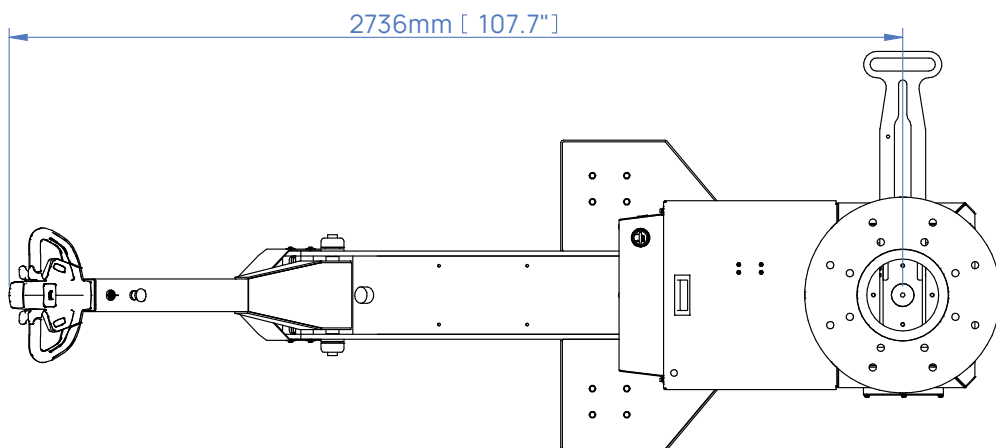
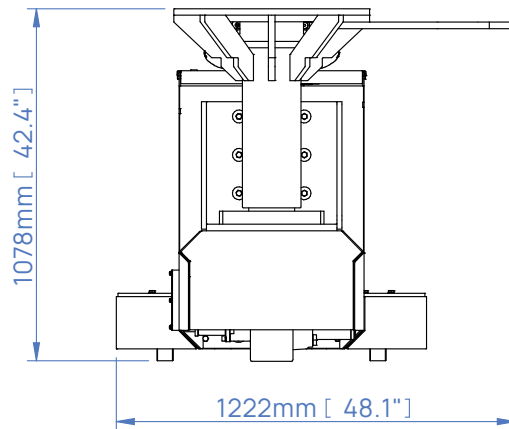
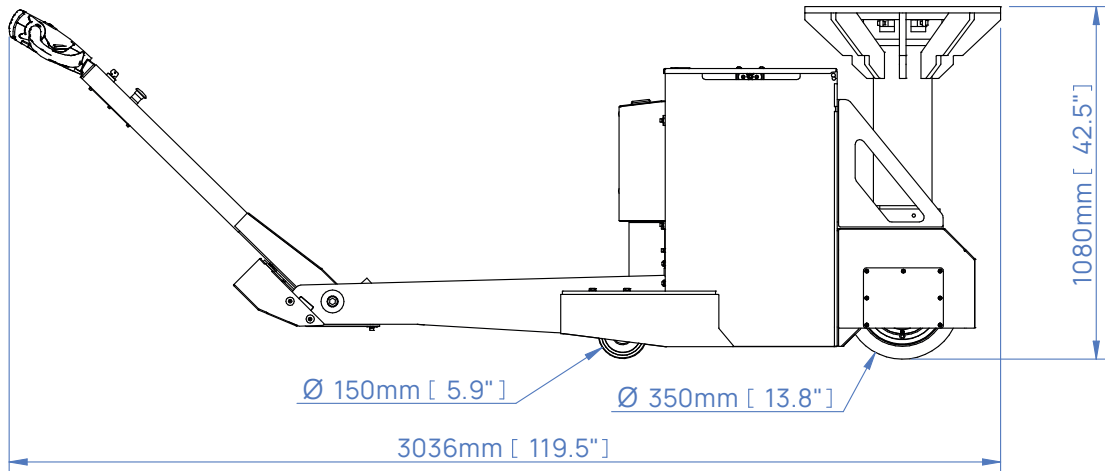



Dimensions





In Application: Trailer Moving System

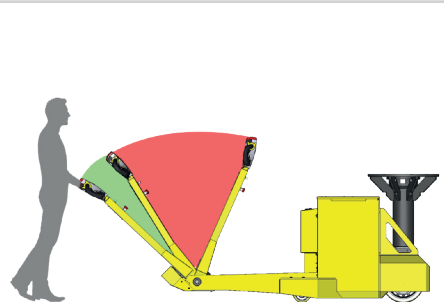

Standard Safety Features

<p>Emergency Stop</p>  A close-up of a red emergency stop button on a yellow panel. The button is circular with a yellow ring and the words "EMERGENCY STOP" around it.	<p>Anti-Crush Button</p>  A close-up of a red and yellow anti-crush button on a grey and blue control panel.	<p>Warning Horn</p>  A close-up of a yellow warning horn button on a blue control panel.
<p>Automatic Parking Brake</p>  A black and white symbol for an automatic parking brake, consisting of a large letter 'P' inside a circle with two curved lines on either side.	<p>Battery Discharge Indicator</p>  A circular digital display with a black face and a yellow background. It shows "BDI 85%" and has the "MM Master Mover" logo at the top.	<p>Automatic Cut Off</p>  A diagram showing a yellow pallet jack with a red silhouette of a person standing next to it. A red shaded area indicates the automatic cut-off zone.
<p>Key Switch</p>  A close-up of a black key switch on a blue panel.		

Machine Options

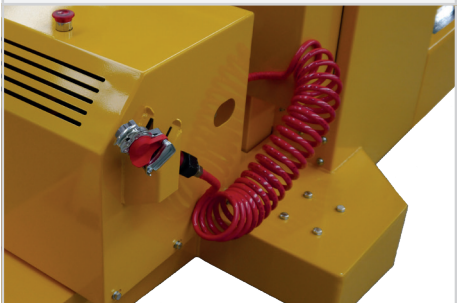
<p>Flashing Light & Motion Beeper Z18-00500</p>	<p>Two Speed Selector Switch Z18-00501</p>	<p>Lift and Tie-Down Points Z18-00504</p>
		
<p>Quick Release Air Compressor Z18-00505</p> 		

Couplings

Mast - 50mm king pin
Z18-00202 male

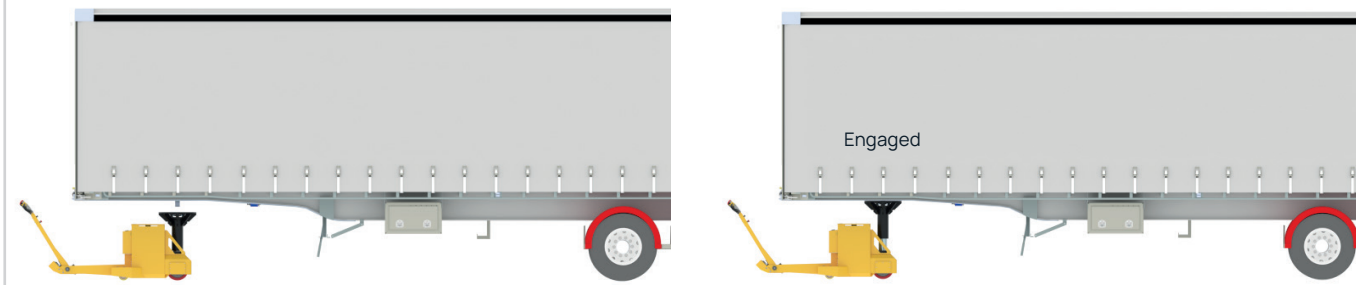

Mast - 90mm king pin
Z18-00203 male

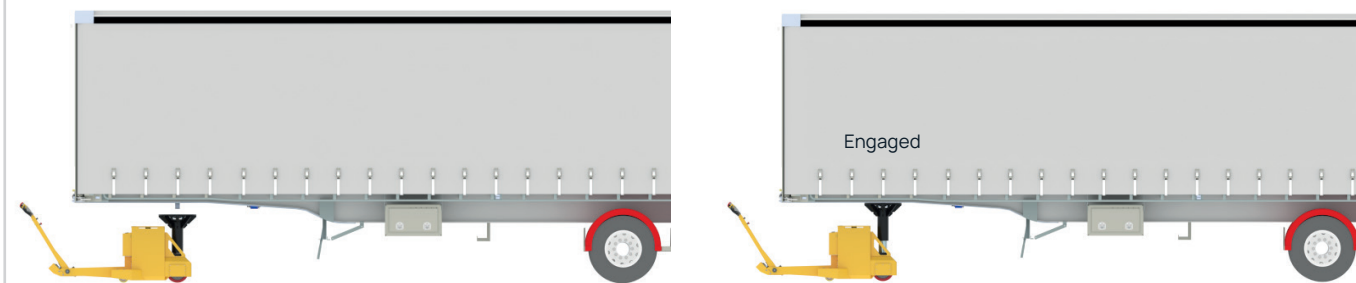

Custom Engineering

We understand that every application is different. Whether it's a custom coupling to connect to your load, modifying our electric tugs to work in a challenging environment, or designing an entirely new solution for your application, our Customer Engineering team are here to help.

For more information on our custom engineering capabilities, please visit: mastermover.com/custom-solutions
If you'd like to discuss your requirements, speak to your sales representative or email: sales@mastermover.com

Technical Specification

Machine	
Product code	Z18-00102
Maximum load (on castors on rails)	11,000 kg 44,000 kg
Maximum force (push pull)	14,715 N 14,715 N
Machine weight	695 kg
Battery weight (standard)	152 kg
Combined machine & battery weight (standard)	847 kg
Drive type	Electric
Braking	Regenerative
Parking brake	Electromagnetic
Drive wheel type	Non-marking Polyurethane
Castor wheel type	Steel
Drive motor power	3 kW
Controller type	AC
Standard machine speed (Without two speed selector switch)	2 KPH
Hare mode speed (With two speed selector switch)	3 KPH
Tortoise mode speed (With two speed selector switch)	1.2 KPH
Maximum slope	7°
Voltage	24 v
Noise level	Motor ≤80 dBA Flashing light ≤85 dBA Horn ≤112 dBA
Metal work finish	Powder coat paint & zinc plated
IP rating	IP44
Wheel diameter	350 mm
Vented Battery	
Product code	Z18-00300
Battery pack capacity	180 Ah
Maximum distance per charge*	8.4 km
Charge time	6 hrs
External Charger	
Product code	Z18-00400
Input voltage	85 - 265 v
Hertz	50 - 60 Hz
Amps	30 A
Phase (single, three)	Single
IP Rating	IP30

Technical Specification

Coupling	
Mast 50mm King Pin (male)	Optional
Mast 90mm King Pin (male)	Optional
Safety	
Key Switch	Standard
Emergency Stop Button	Standard
Battery Discharge Indicator	Standard
Anti-crush Button	Standard
Automatic Parking Brake	Standard
Warning Horn	Standard
Automatic Cut Off (as tiller arm returns to vertical)	Standard
Options	
Flashing Safety Light and Motion Bleeper	Optional
Two Speed Selector Switch	Optional
Lift and Tie-Down Points	Optional
Quick Release Air Compressor	Optional

MasterMover®

mastermover.com

© Copyright 2023

UK
CA

CE

ISO 9001

ISO 45001