

SENSIA EM

REACH TRUCKS

1.6 - 2.5 tonnes

**INTENSIVE PERFORMANCE...
INTUITIVE CONTROL**

A universal reach truck that works exactly how your operators would design a reach truck. It's a big claim. But with the control choices, the adjustability and ergonomics, the performance, the high visibility, the exceptional safety features and more as standard, plus a wide range of optional enhancements, we think you'll see it's a claim we don't make lightly.

SPECIFICATIONS

RB16N3	RB20N3
RB16N3H	RB20N3H
RB16N3HS	RB20N3HX
	RB25N3H

**WHEN
RELIABILITY IS
EVERYTHING...**

RB16-25N3(H)(S)(X) Series



SENSiA EM

RB16-25N3(H)(S)(X) Series

REACH TRUCKS

1.6 – 2.5 tonnes

With lift heights of up to 12 metres, you'll always have a clear view on the load thanks to our MaxVision masts. It maximises visibility, while remaining exceptionally stable. This is a series that prides itself on going that extra step and always in the most efficient way possible.

And while it houses a smart brain, its exterior is tough and highly robust, making it ideal for incredibly intensive operations. Combine that with legendary reliability and low total cost of operation and you'll see why we think so highly of it.

BRAKES

- **Load wheel brakes (option)**
Allows braking with all three wheels for safer operation on lower-friction surfaces such as cold stores.

DRIVE

- **Intelligent Cornering System**
The truck senses the angle of a turn and reduces speed early for maximum stability and accurate, positive cornering.
- **Durable drive wheel**
Low-wear drive wheel means less maintenance and lower costs.

ELECTRICAL AND CONTROL SYSTEMS

- **Motor battery bed (option)**
Motor rollers are available for a quicker one-minute change.
- **Advanced on-board computer**
Stores power and hydraulic preference settings for up to 350 different users.

- **Stability Support System (S3)**
Hydraulic functions such as mast reach and mast tilt are automatically optimised along with a reach damping function to make pallet placement and retrieval safer and quicker.
- **S3 - 2 (option)**
Works to adjust maximum travel speed in relation to actual load weight for the best levels of safety and performance.

FORKS AND MAST

- **MaxVision mast**
This maximises operator field of vision for increased productivity and safety.
- **Level Assistance System (option)**
Automatically detects the operator's intention and automatically stops when the forks are precisely at the right level.
- **Mast Tilt Control (MTC)**
The automatic damping function absorbs unwanted mast movements, reduces the speeds of tilt, side shift and angle, and ensures 80 percent faster mast stabilisation.
- **> 12-metre lift height (X models only)**
Incredibly stable handling even at full height.

FRAME AND BODY

- **Modular design**
Limits the number of parts used meaning service engineers can carry fewer parts to keep the first-time fix rate incredibly high.
- **EasyAccess battery compartment**
This allows quick access for checks and maintenance.
- **Robust chassis**
Built for intensive operations, with great inherent strength and high residual values.

HYDRAULICS

- **Soft Motion**
A finely tuned algorithm adjusts reach, tilt and sideshift speed to greatly improve productivity and handling speed.

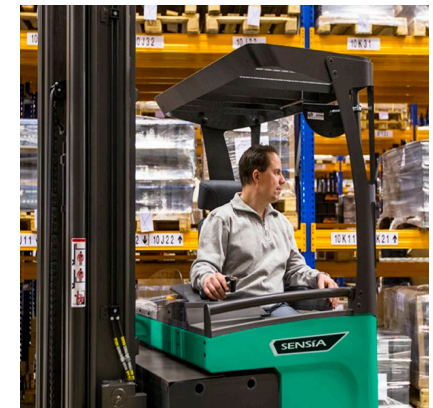
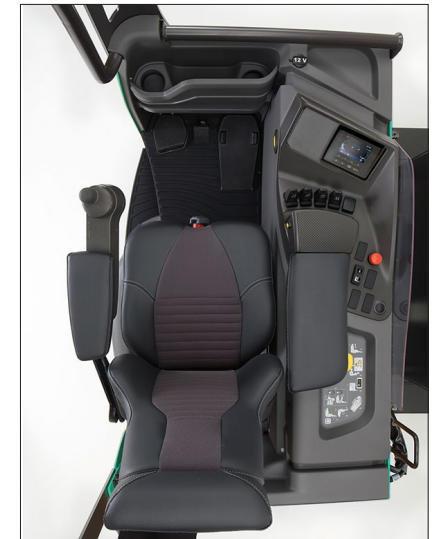

For more information on
SENSiA EM Series
please visit our website



mft2.eu/rb16n3

SENSiA EM

RB16-25N3(H)(S)(X) Series

REACH TRUCKS

1.6 – 2.5 tonnes



OPERATOR COMPARTMENT AND CONTROLS

- **Electrically adjustable floor height**
Can be adjusted to suit each operator and provide a more ergonomic seating position.
- **Tilting seat with ergonomic backrest**
Drivers are kept safe, comfortable, and alert through long shifts.
- **Spacious and comfortable cabin, clear view and fast, accurate fork positioning**
This all helps to increase productivity and reduce risks of driver fatigue — even on the longest shifts.
- **Easy-access compartment**
Includes ergonomic hand bars, low non-slip step and wide entry to provide safe and effortless entry and exit.
- **Multifunctional Ergologic Joystick**
This intuitive and highly ergonomic joystick controls seven different functions, including lifting, lowering, reaching and tilting.
- **Automotive-style pedals**
Pedals are placed in a familiar position for intuitive operation.

- **PIN-code access**
Stops unauthorised truck use and keeps you aware of who's operating at all times.
- **Optional fingertip hydraulic controls**
Integrated, fully adjustable, and allows effortless precision.
- **Motor battery bed (option)**
Motor rollers are available for a quicker one-minute change.

STEERING SYSTEM

- **Mini steering wheel with floating armrest**
Ergonomically adjustable to reduce strain and lower risk of RSI.
- **360-degree steering (option)**
The operator can keep the truck in constant motion — saving seconds on every turn.
- **Midi steering wheel (option)**
Adjustable positioning with tilt function.



For more information on
SENSiA EM Series
please visit our website



OPTIONAL LI-ION BATTERY SYSTEMS

MAKE YOUR FORKLIFT GO EVEN FURTHER

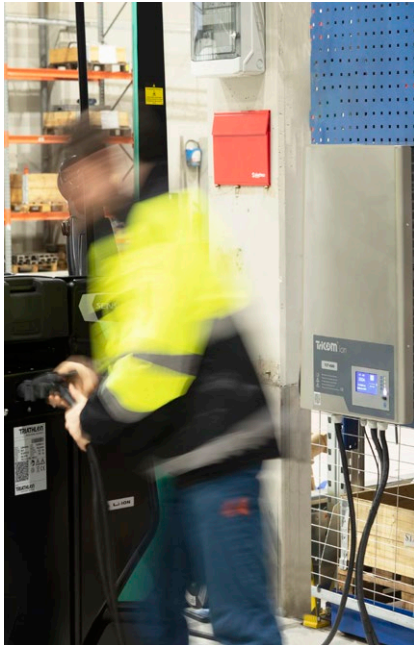

Tried, tested and proven in the field, lead-acid batteries have been the long-standing choice for companies employing electric lift trucks. However, with long charging times, demanding maintenance requirements, the need for extra batteries, and high risk of operator misuse, day-to-day use can be a challenge.

Fortunately, there's a new battery system on the block: Li-ion from Mitsubishi Forklift Trucks.

Designed to meet your business' demands — including multi-shift (24/7) operations — without the need for spare batteries, our high-performance Li-ion battery system is up to 30% more efficient than lead-acid counterparts. Plus, it's virtually error-proof, thanks to its ultra-low-maintenance design which prevents cell damage.

- **Gas-emission free**
No need for air ventilation.



- **Exceptional high battery and charger efficiency**
State-of-the-art technology delivers up to 30% more power efficiency than lead-acid batteries.
- **Maintenance-free design**
No need for daily checks and water re-fills. This reduces the risk of operators damaging cells and reducing their lifetime. Needs a full charge each week to activate cell balancing.
- **No need for spare batteries or charging room**
You can save both space and costs in multi-shift applications, maximising profitability.
- **Quick charge capabilities**
Just 15 minutes is all your battery needs to keep your truck going for a few more hours. It only takes 1 to 2 hours to fully charge a completely discharged battery.
- **Higher sustained voltage**
This gives more consistent lifting and driving performance — particularly noticeable towards the end of a shift.
- **Multiple safety features**
This includes circuit protection, deep-discharge and overcharge protection, and individual cell temperature and voltage monitoring.
- **On-the-go performance and monitoring**
The system's integrated monitoring system has an easy-to-read display unit.
- **Wide choice of battery and charger capacities**
The most suitable power supply can be matched to the exact requirements of a specific application.

Clean Li-ion batteries are ideal for sensitive environments such as those in the food or packaging industries.

Fully integrated Li-ion battery

Features a sophisticated CANbus communication and an automatic ON/OFF synchronization between battery and truck. Battery level, notifications and alarms are integrated into the truck display, to secure clear and easy overview for the truck operator.

For more information on Li-ion please visit our website

VDI - PERFORMANCE & DIMENSIONS

CHARACTERISTICS				Mitsubishi Forklift Trucks	Mitsubishi Forklift Trucks	Mitsubishi Forklift Trucks	Mitsubishi Forklift Trucks
1.1	Manufacturer			RB16N3	RB16N3H	RB16N3HS	RB20N3
1.2	Manufacturer's model designation			Battery	Battery	Battery	Battery
1.3	Power source			Seated	Seated	Seated	Seated
1.4	Operator type			1600	1600	1600	2000
1.5	Load capacity	Q	kg	600	600	600	600
1.6	Load center distance	c	mm	see table	see table	see table	see table
1.8	Load wheel axle to fork face (forks lowered)	x	mm	1448	1420	1420	1530
1.9	Wheelbase	y	mm				
WEIGHT							
2.1b	Truck weight without load, with maximum battery weight		kg	3590	4320	4220	4140
2.3	Axle loadings without load & with maximum battery weight, drive / load side		kg	2000 / 1190	2360 / 1760	2556 / 1930	2290 / 1450
2.4	Axle loading, mast forward, with nominal load, drive / load side		kg	650 / 4140	1040 / 4680	1106 / 4985	550 / 5190
2.5	Axle loading, mast retracted, with nominal load, drive / load side		kg	1750 / 3040	1900 / 3820	2041 / 3965	2040 / 3700
WHEELS, DRIVE TRAIN							
3.1	Tyres: PT = Power Thane, Vul = Vulkollan, P = Polyurethane, N = Nylon, R = Rubber drive / load side			Vul	Vul	Vul	Vul
3.2	Tyre dimensions, drive side		mm	355 x 155	355 x 155	355 x 155	355 x 155
3.3	Tyre dimensions, load side		mm	285 x 105	285 x 105	285 x 75	285 x 105
3.5	Number of wheels, load / drive side (x = driven)			2 / 1 x	2 / 1 x	2 / 1 x	2 / 1 x
3.7	Track width (center of tyres), load side	b11	mm	1128	1128 / 1255	1157	1128 / 1255
DIMENSIONS							
4.1	Fork tilt, forwards / backwards	α, β	°	1 / 4	1 / 4	1 / 4	1 / 4
4.2a	Height with mast lowered	h1	mm	see table	see table	see table	see table
4.3	Free lift	h2	mm	see table	see table	see table	see table
4.4	Lift height	h3	mm	see table	see table	see table	see table
4.5	Height with mast extended	h4	mm	see table	see table	see table	see table
4.7	Height to top of overhead guard	h6	mm	2205	2205	2205	2205
4.8	Seat- or stand height	h7	mm	1153 ¹⁾	1153 ¹⁾	1153 ¹⁾	1153 ¹⁾
4.10	Height of support legs	h8	mm	235	235	305	235
4.15	Fork height, fully lowered	h13	mm	65	65	65	65
4.19	Overall length	l1	mm	see table	see table	see table	see table
4.20	Length to fork face	l2	mm	see table	see table	see table	see table
4.21	Overall width	b1/b2	mm	1270	1270 ²⁾	1270	1270 ²⁾
4.22	Fork dimensions (thickness, width, length)	s/e/l	mm	40 / 100 / 1150	40 / 100 / 1150	40 / 100 / 1150	42 / 100 / 1150
4.23	Fork carriage to DIN			FEM 2A	FEM 2A	FEM 2A	FEM 2A
4.24	Fork carriage width	b3	mm	830	830	830	830
4.25	Outside width over forks (minimum / maximum)	b5	mm	316 - 697	316 - 697	316 - 697	316 - 697
4.26	Inner width of support legs	b4	mm	912	903 ¹⁰⁾	1070	903 ¹⁰⁾
4.28	Mast reach	l4	mm	see table	see table	see table	see table
4.32	Ground clearance at center of wheelbase, (forks lowered)	m2	mm	70	70	70	70
4.33a	Working aisle width (Ast) with 1000 x 1200 mm pallets, load crosswise	Ast	mm	see table	see table	see table	see table
4.34a	Working aisle width (Ast) with 800 x 1200 mm pallets, load lengthwise	Ast	mm	see table	see table	see table	see table
4.35	Turning radius	Wa	mm	see table	see table	see table	see table
4.37	Truck length including support legs	l7	mm	1800	1800	1803	1910
PERFORMANCE							
5.1	Travel speed, with / without load		km/h	12.5 / 12.5	12.5 / 12.5	12 / 12	12.5 / 12.5
5.2	Lifting speed, with / without load		m/s	0.49 / 0.80	0.48 / 0.68	0.48 / 0.68	0.37 / 0.63
5.3	Lowering speed, with / without load		m/s	0.49 / 0.48	0.5 / 0.48	0.5 / 0.48	0.55 / 0.43
5.5	Rated drawbar pull, with / without load		N	0.2 / 0.2	0.2 / 0.2	0.2 / 0.2	0.2 / 0.2
5.8	Maximum gradeability with / without load		%	14.9 / 19.6	11 / 15.2	11 / 15.2	11 / 16.5
5.9	Acceleration time (10 metres) with / without load		s	4.8 / 4.4	5.1 / 4.6	5.1 / 4.6	4.8 / 4.4
5.10	Service brakes (mechanical / hydraulic / electric / pneumatic)			Electric	Electric	Electric	Electric
ELECTRIC MOTORS							
6.1	Drive motor capacity (60 min. short duty)		kW	7.2	7.2	7.2	7.2
6.2	Lift motor output at 15% duty factor		kW	15	15	15	15
6.4	Battery voltage/capacity at 5-hour discharge		V/Ah	48 - 465 / 620 / 775	48 - 620 / 775	48 - 465 / 620 / 775	48 - 620 / 775 / 930
6.5	Battery weight		kg	712 / 892 / 1063	892 / 1063	712 / 892 / 1063	892 / 1063 / 1240
6.6b	Energy consumption according to VDI 60 cycle		kWh / h	5.3	5.3	5.3	5.3
MISCELLANEOUS							
8.1	Type of drive control		bar	Stepless	Stepless	Stepless	Stepless
10.1	Maximum operating pressure for attachments		l / min	150	150	150	150
10.2	Oil flow for attachments		dB(A)	25	25	25	25
10.7	Level of noise at the ear level of the driver according to EN 12 053:2001 and EN ISO 4871 in work LpAZ			60.8	60.8	60.8	60.8

SENSIA EM

RB16-20N3(H)(S) Series REACH TRUCKS

1.6 – 2.0 tonnes



1) Measured with standard seat to SIP point
10) Inner width of 1030mm available
12) b1 1397mm if inner width is 1030mm

VDI - PERFORMANCE & DIMENSIONS

CHARACTERISTICS				Mitsubishi Forklift Trucks	Mitsubishi Forklift Trucks	Mitsubishi Forklift Trucks
1.1	Manufacturer			RB20N3H	RB20N3HX	RB25N3H
1.2	Manufacturer's model designation			Battery	Battery	Battery
1.3	Power source			Seated	Seated	Seated
1.4	Operator type			2000	2000	2500
1.5	Load capacity	Q	kg	600	600	600
1.6	Load center distance	c	mm	see table	see table	see table
1.8	Load wheel axle to fork face (forks lowered)	x	mm	1530	1530	1630
1.9	Wheelbase	y	mm			
WEIGHT						
2.1b	Truck weight without load, with maximum battery weight		kg	4550	5200	4600
2.3	Axle loadings without load & with maximum battery weight, drive / load side		kg	2400 / 1750	2790 / 2410	2400 / 2000
2.4	Axle loading, mast forward, with nominal load, drive / load side		kg	650 / 5500	1060 / 6140	800 / 6100
2.5	Axle loading, mast retracted, with nominal load, drive / load side		kg	2050 / 4100	2280 / 4920	2100 / 4100
WHEELS, DRIVE TRAIN						
3.1	Tyres: PT = Power Thane, Vul = Vulkollan, P = Polyurethane, N = Nylon, R = Rubber drive / load side			Vul	Vul	Vul
3.2	Tyre dimensions, drive side		mm	355 x 155	355 x 155	355 x 155
3.3	Tyre dimensions, load side		mm	285 x 105	285 x 105	285 x 105
3.5	Number of wheels, load / drive side (x = driven)			2 / 1 x	2 / 1 x	2 / 1 x
3.7	Track width (center of tyres), load side	b11	mm	1128 / 1255	1255	1255
DIMENSIONS						
4.1	Fork tilt, forwards / backwards	∅, β	°	1 / 4	1 / 4	1 / 4
4.2a	Height with mast lowered	h1	mm	see table	see table	see table
4.3	Free lift	h2	mm	see table	see table	see table
4.4	Lift height	h3	mm	see table	see table	see table
4.5	Height with mast extended	h4	mm	see table	see table	see table
4.7	Height to top of overhead guard	h6	mm	2205	2205	2205
4.8	Seat- or stand height	h7	mm	1153 ¹⁾	1153 ¹⁾	1153 ¹⁾
4.10	Height of support legs	h8	mm	235	235	235
4.15	Fork height, fully lowered	h13	mm	65	65	65
4.19	Overall length	l1	mm	see table	see table	see table
4.20	Length to fork face	l2	mm	see table	see table	see table
4.21	Overall width	b1/b2	mm	1270 ¹²⁾	1397	1397
4.22	Fork dimensions (thickness, width, length)	s/e/l	mm	40 / 100 / 1150	40 / 100 / 1150	45 / 100 / 1150
4.23	Fork carriage to DIN			FEM 2A	FEM 2A	FEM 2A
4.24	Fork carriage width	b3	mm	830	830	830
4.25	Outside width over forks (minimum / maximum)	b5	mm	316 - 697	316 - 697	316 - 697
4.26	Inner width of support legs	b4	mm	903 ¹⁰⁾	1030	1030
4.28	Mast reach	l4	mm	see table	see table	see table
4.32	Ground clearance at center of wheelbase, (forks lowered)	m2	mm	70	70	70
4.33a	Working aisle width (Ast) with 1000 x 1200 mm pallets, load crosswise	Ast	mm	see table	see table	see table
4.34a	Working aisle width (Ast) with 800 x 1200 mm pallets, load lengthwise	Ast	mm	see table	see table	see table
4.35	Turning radius	Wa	mm	see table	see table	see table
4.37	Truck length including support legs	l7	mm	1910	1910	2010
PERFORMANCE						
5.1	Travel speed, with / without load		km/h	14.3 / 14.5	12 / 12	12 / 12
5.2	Lifting speed, with / without load		m/s	0.37 / 0.63	0.36 / 0.52	0.33 / 0.52
5.3	Lowering speed, with / without load		m/s	0.55 / 0.43	0.54 / 0.45	0.55 / 0.43
5.5	Rated drawbar pull, with / without load		N	0.2 / 0.2	0.2 / 0.2	0.2 / 0.2
5.8	Maximum gradeability with / without load		%	6.3 / 9.4	6.1 / 8.4	9.2 / 14.7
5.9	Acceleration time (10 metres) with / without load		s	4.8 / 4.4	4.8 / 4.4	4.8 / 4.4
5.10	Service brakes (mechanical / hydraulic / electric / pneumatic)			Electric	Electric	Electric
ELECTRIC MOTORS						
6.1	Drive motor capacity (60 min. short duty)		kW	7.2	7.2	7.2
6.2	Lift motor output at 15% duty factor		kW	15	15	15
6.4	Battery voltage/capacity at 5-hour discharge		V/Ah	48 - 620 / 775 / 930	48 - 775 / 930	48 - 775 / 930
6.5	Battery weight		kg	892 / 1063 / 1240	1063 / 1240	1063 / 1240
6.6b	Energy consumption according to VDI 60 cycle		kWh / h	5.3		5.3
MISCELLANEOUS						
8.1	Type of drive control		bar	Stepless	Stepless	Stepless
10.1	Maximum operating pressure for attachments		l / min	150	150	150
10.2	Oil flow for attachments		dB(A)	25	25	25
10.7	Level of noise at the ear level of the driver according to EN 12 053:2001 and EN ISO 4871 in work LpAz			60.8	60.8	60.8

SENSIA EM RB20-25N3(H)(X) Series REACH TRUCKS

2.0 – 2.5 tonnes



1) Measured with standard seat to SIP point
10) Inner width of 1030mm available
12) b1 1397mm if inner width is 1030mm

MAST PERFORMANCE AND CAPACITY

SENSIA EM

RB16-25N3(H)(S)(X) Series

MAST TYPE	h3 + h13 mm	h1 mm	h2 + h13 mm	h4 mm
RB16N3 - RB20N3				
DTFV TRIPLEX	4800	2153	1645	5345
	5400	2353	1845	5945
	5700	2453	1945	6245
	6300	2653	2145	6845
	6750	2803	2295	7295
	7250	2970	2462	7795
	7950	3203	2695	8495
	8450	3370	2862	8995
8950	3536	3028	9495	
RB16N3H				
DTFV TRIPLEX	6350	2972	2432	6890
	7050	3205	2665	7590
	7550	3372	2832	8090
	8050	3538	2998	8590
	8500	3688	3148	9040
	8950	3838	3298	9490
	9600	4055	3515	10140
	10200	4255	3715	10740
10800	4455	3915	11340	
RB16N3HS				
DTFV TRIPLEX	6350	2972	2432	6890
	7050	3205	2665	7590
	7550	3372	2832	8090
	8050	3538	2998	8590
	8500	3688	3148	9040
	9600	4055	3515	10140
RB20N3H				
DTFV TRIPLEX	6350	2970	2462	6895
	7050	3203	2695	7595
	7550	3370	2862	8095
	8050	3536	3028	8595
	8500	3686	3178	9045
	8950	3836	3328	9495
	9600	4053	3545	10145
	10200	4253	3745	10745
10800	4453	3945	11345	
11500	4686	4178	12046	

h3+h13 = Lifting height
h1 = Lowered mast height
h2+h13 = Free lift
h4 = Raised mast height

MAST TYPE	h3 + h13 mm	h1 mm	h2 + h13 mm	h4 mm
RB20N3HX				
DTFV TRIPLEX	9600	4053	3545	10145
	10200	4253	3745	10745
	10800	4453	3945	11345
	11100	4553	4045	11645
	11600	4720	4210	12145
	12100	4886	4378	12645
RB25N3H				
DTFV TRIPLEX	4800	2450	1795	5490
	5850	2800	2145	6540
	6350	2967	2312	7040
	7050	3200	2545	7740
	7550	3367	2712	8240
	8050	3533	2878	8740
	8500	3683	3028	9190
	8950	3833	3178	9640

MODEL	BATTERY CAPACITY	BATTERY WEIGHT	4.33a	4.34a	4.28	4.20	4.19	1.8	4.35
	Ah	kg	AST mm	AST mm	L4 mm	L2 mm	L1 mm	x mm	Wa mm
RB16N3	465	708	2689	2728	596	1229	2379	439	1668
	620	892	2740	2792	524	1301	2451	367	1668
	775	1063	2794	2857	452	1373	2535	295	1668
	620	892	2761	2823	490	1335	2485	306	1643
RB16N3H	775	1063	2816	2889	418	1407	2557	234	1643
	465	712	2708	2758	565	1263	2413	381	1643
RB16N3HS	620	892	2761	2823	493	1335	2485	309	1643
	775	1063	2816	2889	421	1407	2557	237	1643
RB20N3	620	892	2770	2808	625	1310	2460	551	1750
	775	1063	2821	2873	553	1382	2532	369	1750
	930	1240	2875	2938	481	1454	2604	297	1750
RB20N3H	620	892	2788	2831	600	1335	2485	416	1750
	775	1063	2839	2895	528	1407	2557	344	1750
	930	1240	2894	2961	456	1479	2629	272	1750
RB20N3HX	930	1240	2906	2976	430	1495	2645	256	1750
RB25N3H	775	1063	2871	2910	628	1412	2562	439	1850
	930	1240	2921	2974	556	1484	2634	367	1850

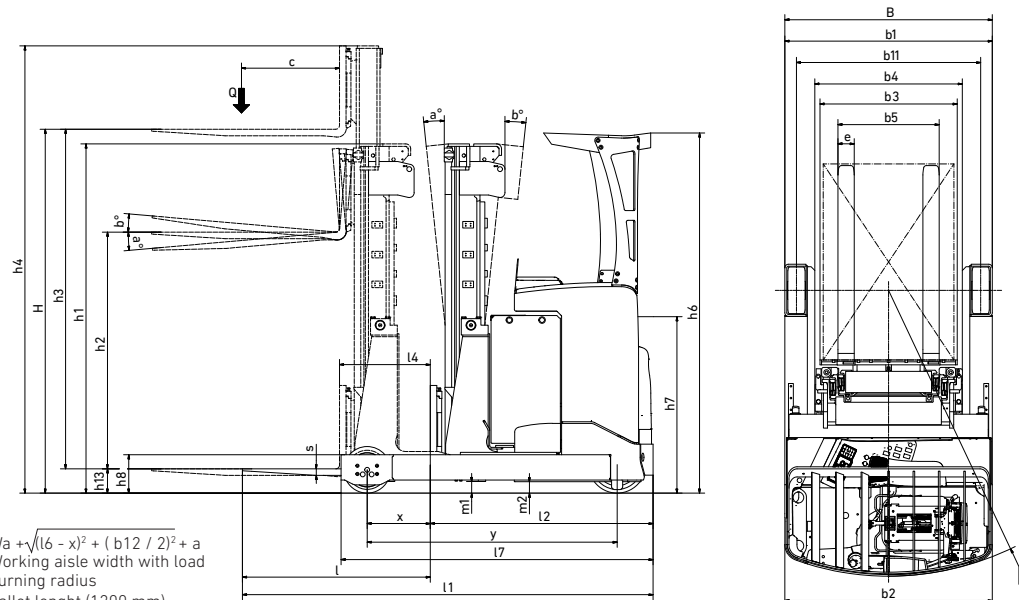

STANDARD EQUIPMENT & OPTIONS

- = Standard
- = Option

	RB16N3	RB16N3H	RB16N3HS	RB20N3	RB20N3H	RB25N3H	RB20N3HX
GENERAL							
Automatic electric parking brake	●	●	●	●	●	●	●
Steering wheel angle indicator	●	●	●	●	●	●	●
Battery indicator with cut out at 20% remaining battery level	●	●	●	●	●	●	●
Multifunctional colour display	●	●	●	●	●	●	●
Integrated sideshift DTFV mast	●	●	●	●	●	●	●
Electric adjustable floor height	●	●	●	●	●	●	●
Suspension seat with weight-controlled tilting high backrest	●	●	●	●	●	●	●
Increased drive speed 14.5 km/h	●	●	●	●	●	-	-
Chill store design, down to +1° Celsius	●	●	●	●	●	●	●
Paper storage and cup holder	●	●	●	●	●	●	●
Battery reach out	●	●	●	●	●	●	●
Battery on rollers	●	●	●	●	●	●	●
Motor power battery bed	●	●	●	●	●	●	●
Other RAL-colour	●	●	●	●	●	●	●
POWER SOURCE							
Li-ion battery*	●	●	●	●	●	●	●
Lead acid battery	●	●	●	●	●	●	●
Battery cover plate	●	●	●	●	●	●	●
MAST, FORKS AND CARRIAGE							
Tilting mast	●	●	●	●	●	●	-
Fork tilt	●	●	●	●	●	●	●
Integral fork positioner/sideshift DTFV mast	●	●	●	●	●	●	-
Load backrest	●	●	●	●	●	●	●
Load backrest in combination with fork positioner/sideshift	●	●	●	●	●	●	-
Mast Tilt Control, MTC (std @ lift height > 7.2 m, Option < 7.2 m)	●	●	●	●	●	●	-
Lift stop with-/without restart	●	●	●	●	●	●	●
Lift height indicator (std in S3-2 Increased performance)	●	●	●	●	●	●	●
Level selector	●	●	●	●	●	●	●
Level assistance system, LAS	●	●	●	●	●	●	●
Load weight indicator (std in S3-2 Increased performance)	●	●	●	●	●	●	●
Fork camera with RLED display	●	●	●	●	●	●	●
Horizontal forks	●	●	●	●	●	●	●
Central position of sideshift	●	●	●	●	●	●	●
S3 - Stability Support System with Soft Motion	●	●	●	●	●	●	●

* Not in combination Cold store design, 0C° to -30C°

SENSIA EM RB16-25N3(H)(S)(X) Series REACH TRUCKS

1.6 – 2.5 tonnes



Multifunctional colour display



Suspension seat with tilting backrest



Blue point safety light

STANDARD EQUIPMENT & OPTIONS

● = Standard
● = Option

	RB16N3	RB16N3H	RB16N3HS	RB20N3	RB20N3H	RB25N3H	RB20N3HX
DRIVE AND LIFT CONTROLS							
Electric power mini steering in floating armrest	●	●	●	●	●	●	●
180-degree steering	●	●	●	●	●	●	●
360-degree steering	●	●	●	●	●	●	●
Active Spin Reduction	●	●	●	●	●	●	●
Intelligent Cornering System (ICS)	●	●	●	●	●	●	●
Hands-free direction control, HFDC, in accelerator pedal	●	●	●	●	●	●	●
Hand-operated direction control	●	●	●	●	●	●	●
Ergologic Joystick	●	●	●	●	●	●	●
Fingertip controls	●	●	●	●	●	●	●
Midi steering wheel	●	●	●	●	●	●	●
Key switch entry	●	●	●	●	●	●	●
Creep speed at preset level 500 mm	●	●	●	●	●	●	●
Creep speed at other levels	●	●	●	●	●	●	●
S3-2 Increased performance	●	●	●	●	●	●	●
ELECTRIC							
Blue / Red point safety light, towards driving direction	●	●	●	●	●	●	●
Automatic logoff	●	●	●	●	●	●	●
Working lights LED	●	●	●	●	●	●	●
Working lights LED for cabin	●	●	●	●	●	●	●
Warning light on the roof	●	●	●	●	●	●	●
Warning light for Heated cabin	●	●	●	●	●	●	●
12 V connector	●	●	●	●	●	●	●
Converter 48 - 12 V	●	●	●	●	●	●	●
Radio with MP3	●	●	●	●	●	●	●
Service alarm	●	●	●	●	●	●	●
OHG AND CABIN							
Heated cabin**	●	●	●	●	●	●	●
Window opening in cabin door (CSM)	●	●	●	●	●	●	●
2-way intercom for cold store cabin (CSM)	●	●	●	●	●	●	●
Panoramic MaxVision roof	●	●	●	●	●	●	●
Mesh metal on overhead guard	●	●	●	●	●	●	●
Heated seat – fabric	●	●	●	●	●	●	●
Heated seat – PVC	●	●	●	●	●	●	●
Headrest for seat	●	●	●	●	●	●	●
Rear view mirror	●	●	●	●	●	●	●
Writing desk	●	●	●	●	●	●	●
Equipment holder, RAM system size C	●	●	●	●	●	●	●
Equipment holder, RAM system size C, 2 pcs	●	●	●	●	●	●	●
Equipment holder, RAM system size D	●	●	●	●	●	●	●
WHEEL OPTIONS							
Vulkolan® traction wheel 93 Shore	●	●	●	●	●	-	●
Vulkolan® traction wheel 95 Shore	●	●	●	●	●	●	●
Tractothan® traction wheel 93 Shore	●	●	●	●	●	●	●
Load wheel Ø 230mm	●	●	●	●	●	-	●
Load wheel Ø 285mm	-	●	●	●	●	●	●
Load wheel brakes, incl. Ø 285mm load wheel	-	●	●	●	●	●	●
Load wheel covers	●	●	●	●	●	●	●
ENVIRONMENT							
Cold store design, 0C° to -30C°**	●	●	●	●	●	●	●

** Not in combination with Li-ion battery

SENSIA EM RB16-25N3(H)(S)(X) Series REACH TRUCKS

1.6 – 2.5 tonnes



Ergologic joystick



Midi steering wheel



2-way intercom for cold store cabin

WHEN RELIABILITY IS EVERYTHING...



Like any product bearing the Mitsubishi Forklift Trucks name, our materials handling equipment benefits from the tremendous heritage, huge resources and cutting-edge technology of one of the world's largest corporations – Mitsubishi Heavy Industries Group.

Engineering spacecraft, jet planes, power plants and more, MHI specialises in those technologies where performance, dependability and superiority decide your success or failure...

So when we promise you quality, reliability and value for money, you know it's a guarantee we have the power to deliver.

That's why every model in our award winning and comprehensive range of lift trucks and warehouse equipment is built to a high specification – to ensure it keeps working for you. Day after day. Year after year. Whatever the job. Whatever the conditions.

YOU'LL NEVER WORK ALONE

As your local authorised distributor, we are here to keep your trucks working – through our extensive experience, our technical excellence and our commitment to customer care.

We are your local experts, backed by efficient channels to the entire organisation of Mitsubishi Forklift Trucks.

No matter where you are, we are close by – with the capability to meet your needs.

Discover how Mitsubishi Forklift Trucks give you more from your local authorised distributor or when you visit our website www.mitforklift.com

Performance specifications may vary depending on standard manufacturing tolerances, vehicle condition, types of tyres, floor or surface conditions, applications or operating environment. Trucks may be shown with non-standard options.

Specific performance requirements and locally available configurations should be discussed with your distributor.

We follow a policy of continual product improvement. For this reason, some materials, options and specifications could change without notice.

QUALITY | RELIABILITY | VALUE FOR MONEY

info@mitforklift.com

WESM2279 (07/24) © 2024 MLE

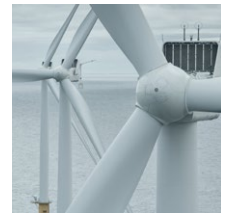

Mitsubishi Logisnext Europe B.V.
Hefbrugweg 77, 1332 AM Almere
The Netherlands
Tel: +31 (0)36 5494 411



mft2.eu/fb



mft2.eu/apps



mft2.eu/youtube



mft2.eu/facebook

